

# ValuFlo® 1000

## INSTALLATION AND SERVICE MANUAL

FILL IN FOR FUTURE REFERENCE:

MODEL: \_\_\_\_\_  
 SERIAL NUMBER: \_\_\_\_\_  
 DATE PURCHASED: \_\_\_\_\_

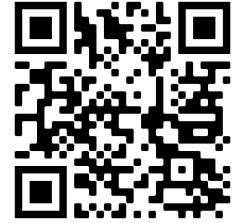
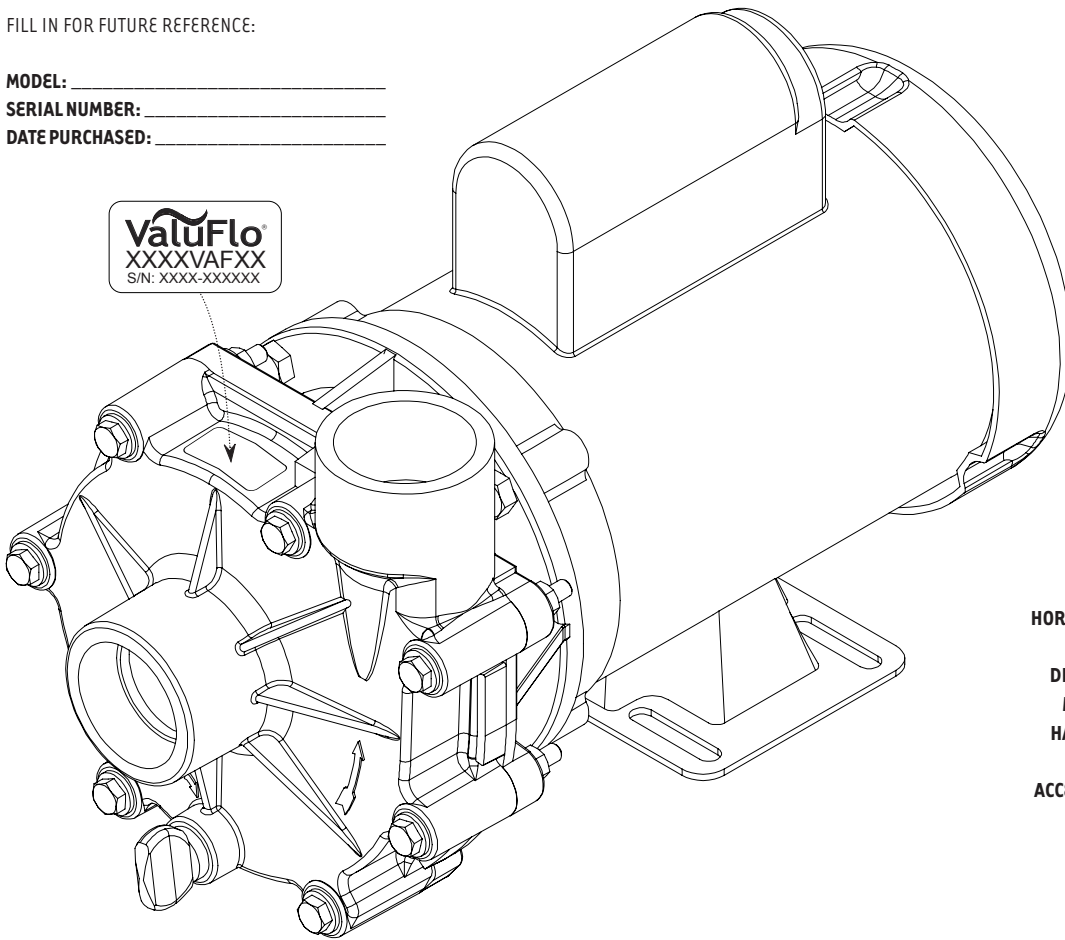

TO REGISTER YOUR PUMP  
 SCAN THIS QR CODE OR VISIT  
[MDMINC.COM/PUMP-REGISTRATION](http://MDMINC.COM/PUMP-REGISTRATION)

- TYPE:** STRAIGHT CENTRIFUGAL
- MOTOR:** NEMA C FACE, 56J
- HORSEPOWER:** 1/3, 1/4, 1/6, 1/8 (1750 RPM)
- INLET:** 1-1/2" FNPT
- DISCHARGE:** 1-1/2" FNPT
- MATERIAL:** 40% GLASS-FILLED POLYPROPYLENE
- HARDWARE:** STAINLESS STEEL
- OPTIONS:** SALTWATER SERVICE
- ACCESSORIES:** 90 CUBIC INCH STRAINER BASKETS (1.5" & 2")  
 500 CUBIC INCH STRAINER BASKET (2")  
 SWING CHECK VALVES (1.5", 2", 3")

*\*MOTORS ARE SUBJECT TO CHANGE DUE TO AVAILABILITY OR SPECIFICATION REQUIREMENTS.*

Model	3300VAF21	4500VAF21	5100VAF22	6100VAF23
INLET	1.5"	1.5"	1.5"	1.5"
DISCHARGE	1.5"	1.5"	1.5"	1.5"
MAX FLOW (gph)	3300	4500	5100	6100
MAX HEAD (feet)	21'	21'	22'	23'
MAX POWER (watts)	215	253	293	344
MAX CURRENT (amps)	1.9 @ 115V	2.2 @ 115V	2.6 @ 115V	3.0 @ 115V
VOLTS	115/230	115/230	115/230	115/230
MOTOR HP	1/3, 1/4, 1/6, 1/8	1/3, 1/4, 1/6, 1/8	1/3, 1/4, 1/6, 1/8	1/3, 1/4, 1/6, 1/8
MOTOR TYPE	56J	56J	56J	56J
MOTOR ENCLOSURE	TEFC	TEFC	TEFC	TEFC
IMPELLER	4	5	6	7



**Read this manual completely before you install or operate your new pump. This is an external "out-of-pond" pump. It is not submersible. Do not allow this pump to become submerged. Never run dry. Maximum case pressure - 65 PSI.**



PROUDLY MADE  
 IN THE USA

*Economy with efficiency.*

© MDM INCORPORATED  
[WWW.MDMINC.COM](http://WWW.MDMINC.COM)

# ValuFlo® 1000

We congratulate you on your choice of the ValuFlo® 1000 Centrifugal Pump. It has been carefully designed using the advantages of today's technology and carefully constructed to give you the dependability of yesterday. To insure proper performance, we urge you to carefully follow the instructions in this manual. If you have any questions, please call your supplier for assistance or visit [www.mdminc.com/support](http://www.mdminc.com/support).

## INSTALLATION

**Please read carefully. When properly installed the ValuFlo® 1000 will provide dependable trouble-free service.**

1. Locate the pump as near the water source as possible. A flooded suction situation is preferred. The pump is not self-priming, therefore, if the fluid level is below the pump, a swing check valve must be installed and the pump primed prior to start-up (Figure 1). It must not be run dry.
2. Mount Motor base to a secure, immobile foundation.
3. Use only plastic fittings on both the intake and discharge ports. Seal pipe connections with Teflon® paste. These fittings should be self-supported and in neutral alignment with each port (i.e. Fittings must not be forced into alignment which may cause premature line failure or damage to the pump volute). A strainer basket is recommended for non-flooded installations.
4. Never restrict the intake. Keep both input and discharge lines as free of elbows and valves as possible. Always use pipe of adequate diameter. This will reduce friction losses and maximize output.

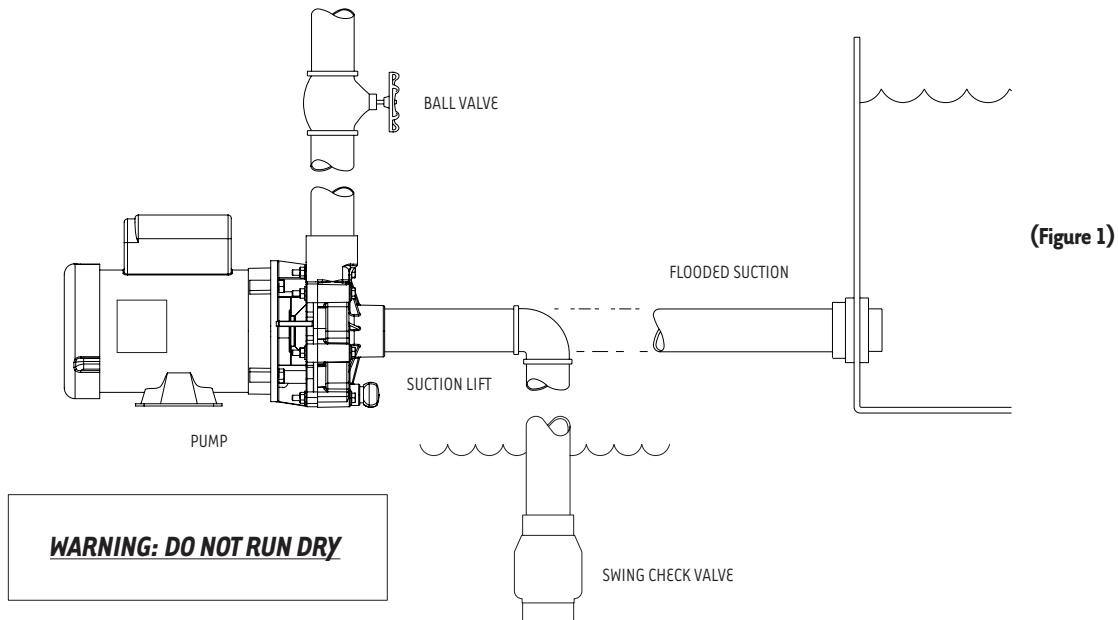

### **WARNING: ALWAYS SHUT OFF ELECTRICAL POWER BEFORE INSTALLATION AND / OR SERVICING THIS PUMP.**

ALL ELECTRICAL WIRING SHOULD MEET STATE AND LOCAL ORDINANCES. IMPROPER WIRING MAY NOT ONLY BE A SAFETY HAZARD BUT MAY PERMANENTLY DAMAGE THE MOTOR AND/OR PUMP. 230V 50HZ MOTORS ARE AVAILABLE. CONTACT YOUR SUPPLIER FOR INFORMATION.

## ELECTRICAL HOOK-UP

1. Check that supply voltages match the Motor's requirements.
2. Check Motor wiring and connect, according to instructions on Motor, to match supply voltage.
3. Power cord should be protected by conduit or by cable and be of proper gauge. It should be no longer than necessary.
4. Power should be drawn directly from a box with circuit breaker protection or with a fused disconnect switch.



PROUDLY MADE  
IN THE USA

*Economy with efficiency.*

© MDM INCORPORATED  
WWW.MDMINC.COM

P.2

# ValuFlo® 1000

## PUMP END ASSEMBLY

1. Inspect all pump parts (O-ring, O-ring groove, Impeller Hub ID, Motor Shaft, etc.) and clean if necessary.
2. Apply sealant to the Bracket Bore ID wall and around the Seal Case. Follow sealant manufacturer instructions. We recommend using Gasegacinch® sealant. Silicone sealant is also acceptable.
3. Press Carbon Graphite Seal into Bracket while taking care not to damage Carbon Graphite Face.
4. Place Slinger (rubber washer) over Motor Shaft.
5. Carefully, lubricate the Seal Seat Elastomer OD and Impeller Hub ID with water. Press the Seal Seat into the Impeller Hub making certain that the ceramic is in evenly - the sealing surface should be parallel with the Impeller Hub.
6. Carefully lubricate carbon-graphite and ceramic sealing surfaces with clean water. Do not use silicon lubricants or grease.
7. Assemble Bracket to Motor with (4) M-bolts.
8. Thread Impeller onto Shaft and tighten. If required, remove Motor End-Cap and use a screwdriver on the back of Motor Shaft to prevent shaft rotation while tightening. Replace Motor End Cap.
9. Seat large O-ring in Volute slot and assemble Volute to Bracket with (7) 1/4" - 20 threads per inch x 2 3/4" Hex Cap Screws, Washers and Nuts. Tighten in a cross pattern (30 inch-pounds force).
10. Install Drain Plug with its O-ring in Volute drain hole.
11. Before operating pump, allow a proper cure time for the sealant used in step 2.

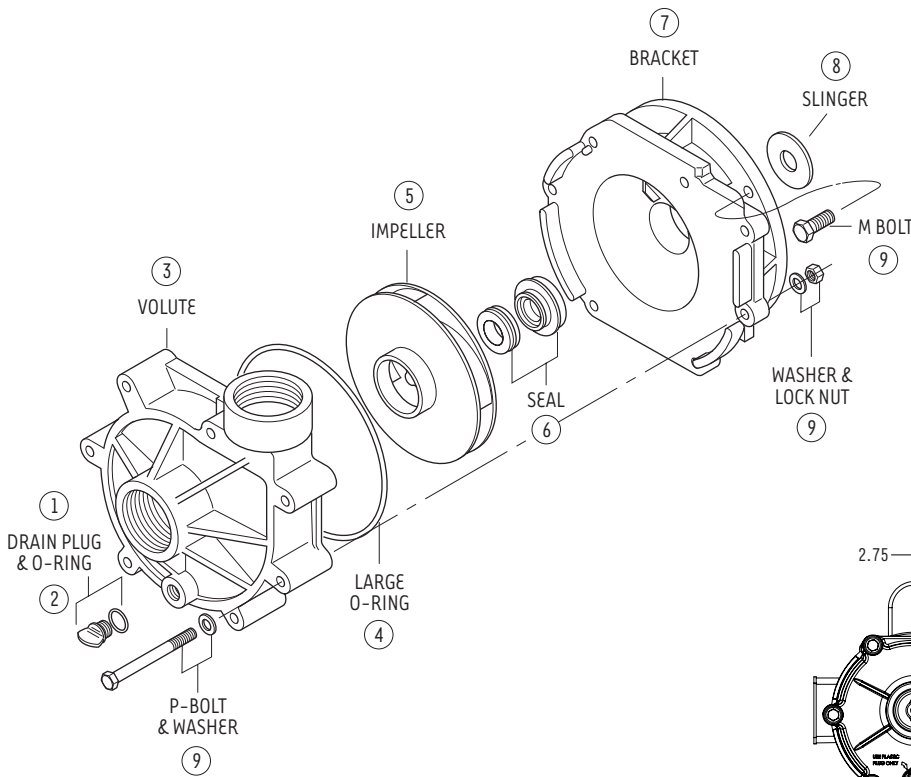

NO.	DESCRIPTION	VALUFLO® P/N
1	DRAIN PLUG	1000.110 LG
2	O-RING (DRAIN PLUG)	E014B70
3	VOLUTE	K000.070 LG
4	LARGE O-RING	1000.061
5	IMPELLER	1000.05__*
6	SEAL - SS316	1000.0414
7	BRACKET	K000.030 LG
8	SLINGER	1000.010V
9	HARDWARE KIT (7) P-BOLTS, (14) WASHERS, (7) LOCK NUTS, (4) M-BOLTS	1000.502

Note: These part numbers are only for standard models within the ValuFlo® 1000 series. 1000.05\_\_\*. \*Consult Factory for Impeller part number.

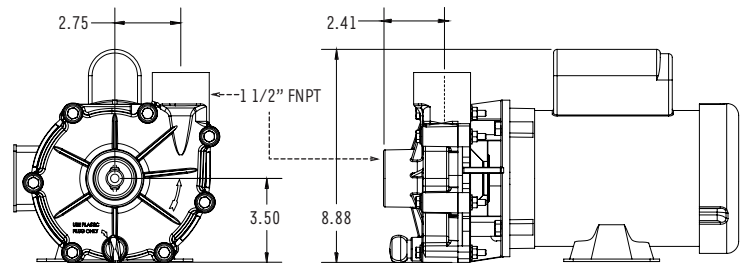

Motor illustration is for reference only.

## DISASSEMBLY

1. Shut off power to motor before disconnecting any electrical wiring from the back of the Motor.
2. Disassemble Volute from Bracket by removing the (7) 1/4" - 20 threads per inch x 2 3/4" Hex Cap Screws.
3. Remove cap covering shaft at back of Motor and with a large screwdriver, prevent shaft rotation while unscrewing Impeller.
4. Remove ceramic piece from Impeller (If you are replacing the Seal).
5. Detach Bracket from Motor.
6. Remove Carbon-Graphite Seal from Bracket by pressing out from the back. Do not dig out from the front (If you are replacing the Seal).



PROUDLY MADE  
IN THE USA

*Economy with efficiency.*

© MDM INCORPORATED  
WWW.MDMINC.COM

P.3

# ValuFlo® 1000

## MAINTENANCE

### Lubrication

Motor - Permanently Lubricated ball bearings - no service required.  
 Rotary Seal - Requires no lubrication after assembly.

## WARNING: EYE PROTECTION IS STRONGLY RECOMMENDED

*\*The pump must be drained before servicing or if stored below freezing temperatures. Periodic replacement of seals may be required due to normal carbon wear.*

SYMPTOM	PROBLEM	RESOLUTION
No Flow	Insufficient Prime	Prime system with water and purge all air from suction piping.
		Install check valve.
	Insufficient Power	Verify power supply and connection from panel to pump.
		Verify proper voltage. Some models are dual voltage (115/230).
	Flow Restriction	Ensure valves are open.
		Ensure plumbing is clear, including suction strainers, check valves, etc.
		Verify check valve orientation and direction of permitted flow.
Air leak	Clean out leaves or other debris from basket strainer (if applicable).	
System Incompatibility	Fix air leaks at fittings, connections, strainer basket etc. This typically occurs on the intake side.	
Low Flow	Air leak	Verify hydraulic compatibility: i.e. pump & pipe are sized for the system.
	System Incompatibility	Fix air leaks at fittings, connections, strainer basket etc. This typically occurs on the intake side.
	Insufficient Power	Verify power supply and connection from panel to pump.
		Verify proper voltage. Some models are dual voltage (115/230).
	Flow Restriction	Ensure valves are open.
		Ensure plumbing is clear, including suction strainers, check valves, etc.
		Clean out leaves or other debris from basket strainer (if applicable).
	Insufficient Prime	Prime system with water and purge all air from suction piping.
	Cavitation	Verify airtight plumbing on the suction plumbing especially fittings.
		Clean out leaves or other debris from basket strainer (if applicable).
Increase pipe size where possible.		
Decrease suction pipe length, reduce the number of elbows, etc.		
Sporadic Operation	Insufficient Power	Verify hydraulic compatibility: i.e. pump and pipe are sized for the system.
		Verify power supply and connection from panel to pump.
Excessive Noise	Cavitation	Verify proper voltage. Some models are dual voltage (115/230).
		Ensure adequate airflow over motor to prevent overheating.
		Verify airtight plumbing on the suction plumbing especially fittings.
		Clean out leaves or other debris from basket strainer (if applicable).
		Increase pipe size where possible.
	Insufficient Power	Decrease suction pipe length, reduce the number of elbows, etc.
		Verify hydraulic compatibility: i.e. pump and pipe are sized for the system.
	Flow Restriction	Verify power supply and connection from panel to pump.
		Verify proper voltage. Some models are dual voltage (115/230).
		Ensure valves are open.
Flow Restriction	Flow Restriction	Ensure plumbing is clear, including suction strainers, check valves, etc.
		Verify check valve orientation and direction of permitted flow.



**MDM INCORPORATED**  
 3345 N. Cascade Ave • Colorado Springs, CO • 80907  
 Phone (719) 634-8202 • Fax (866) 425-1346  
 www.mdminc.com • sales@mdminc.com

Gasgacinch® is a registered trademark of Porter Manufacturing.  
 Teflon® is a registered trademark of the Chemours Corporation.  
 ValuFlo® is a registered trademark of MDM Incorporated.  
 ValuFlo 1000 Installation Manual.indd. Adobe Indesign CC. Updated 3/12/25.



PROUDLY MADE  
 IN THE USA

*Economy with efficiency.*

© MDM INCORPORATED  
 WWW.MDMINC.COM

P.4