

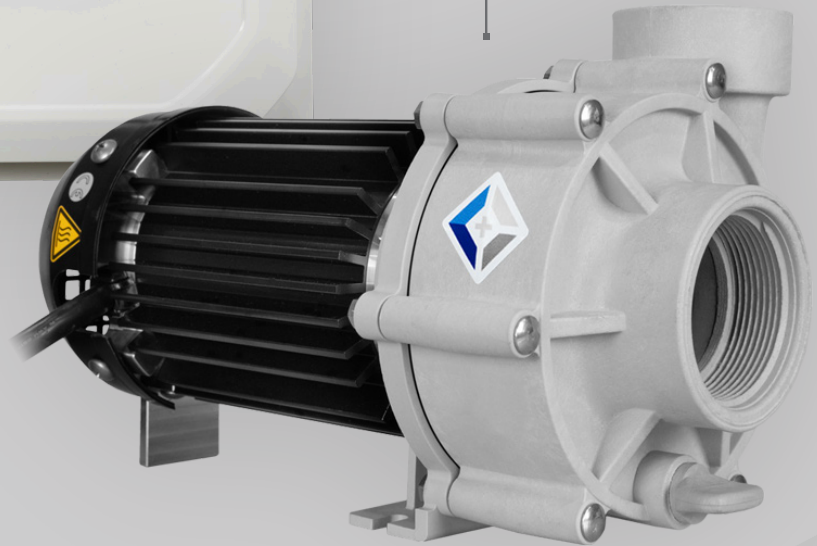

DC MOTOR  
VARIABLE SPEED  
PUMP

SPEED  
CONTROLLER  
& POWER SUPPLY



## COLOSSAL PERFORMANCE & CONTROL

The MDM Sequence® product family introduces the Colossus 750 DC+, a compact, speed controllable, 7200 GPH pump offering direct as well as remote control through third party Internet of Things (IoT) modules. The recent Colossus impeller technology boasts a 16% increase in flow over the synchronous speed legacy impeller designs. Now with speed control capability and energy efficiency that comes with DC motor technology, the performance benefits address the ever-growing demand of high flow, low energy consumption, and small form factor.

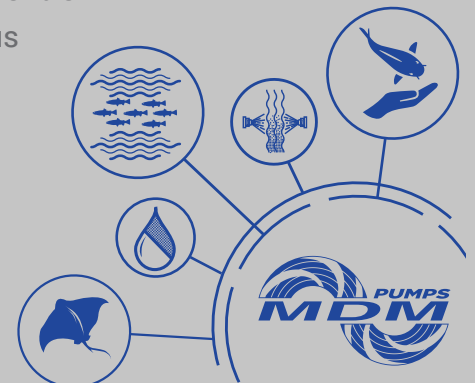

719.634.8202 | [sequencepumps.com](http://sequencepumps.com) | Manufactured in Colorado, USA.  
Sequence® is a registered trademark of MDM Incorporated.

SPEED CONTROLLER & POWER SUPPLY

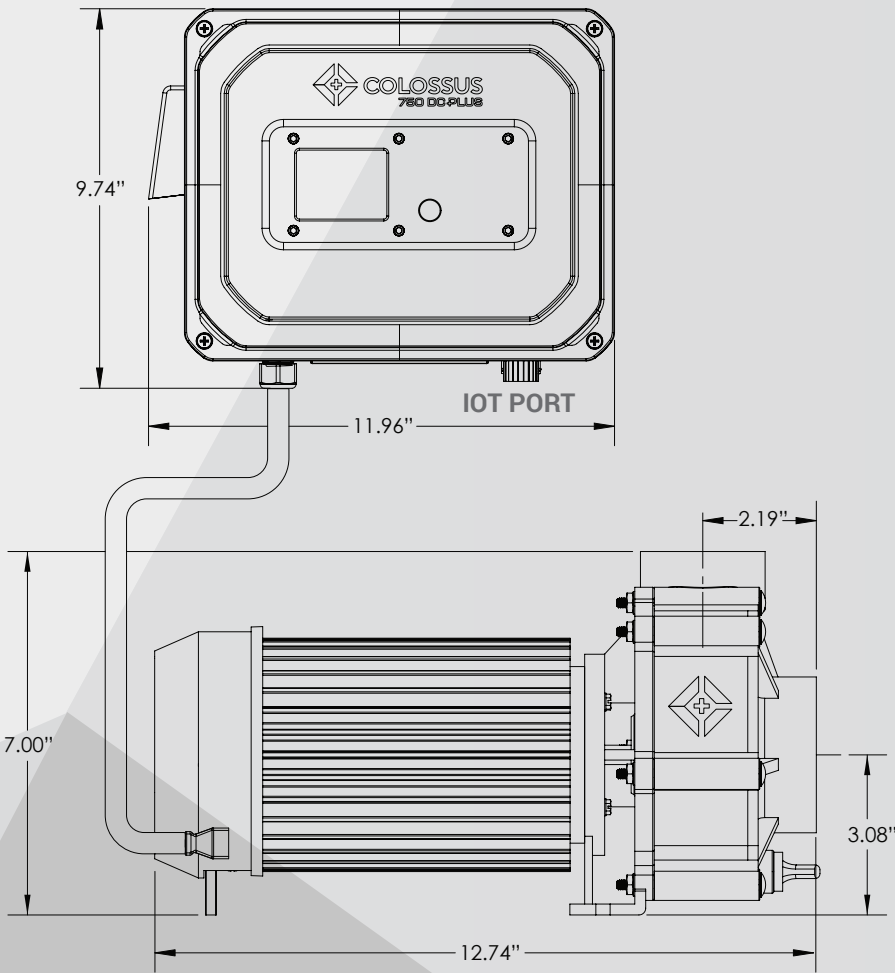

FEATURES

- Overload & Run-Dry Protection
- IoT Controller Ready
- Compact Footprint
- Five Year Warranty
- 7200 GPH Max\*
- 39 Feet Max\*
- Wide Range Speed Control
- Quiet Operation

COLOSSUS 750 DC PLUS

