

# INSTALLATION AND SERVICE MANUAL

FILL IN FOR FUTURE REFERENCE:

MODEL: \_\_\_\_\_  
 SERIAL NUMBER: \_\_\_\_\_  
 DATE PURCHASED: \_\_\_\_\_

*\*MOTORS ARE SUBJECT TO CHANGE DUE TO AVAILABILITY OR SPECIFICATION REQUIREMENTS.*

**ADVANCE**  
 XXXXXXXXX  
 S/N: XXXX-XXXXXX

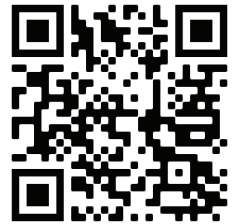
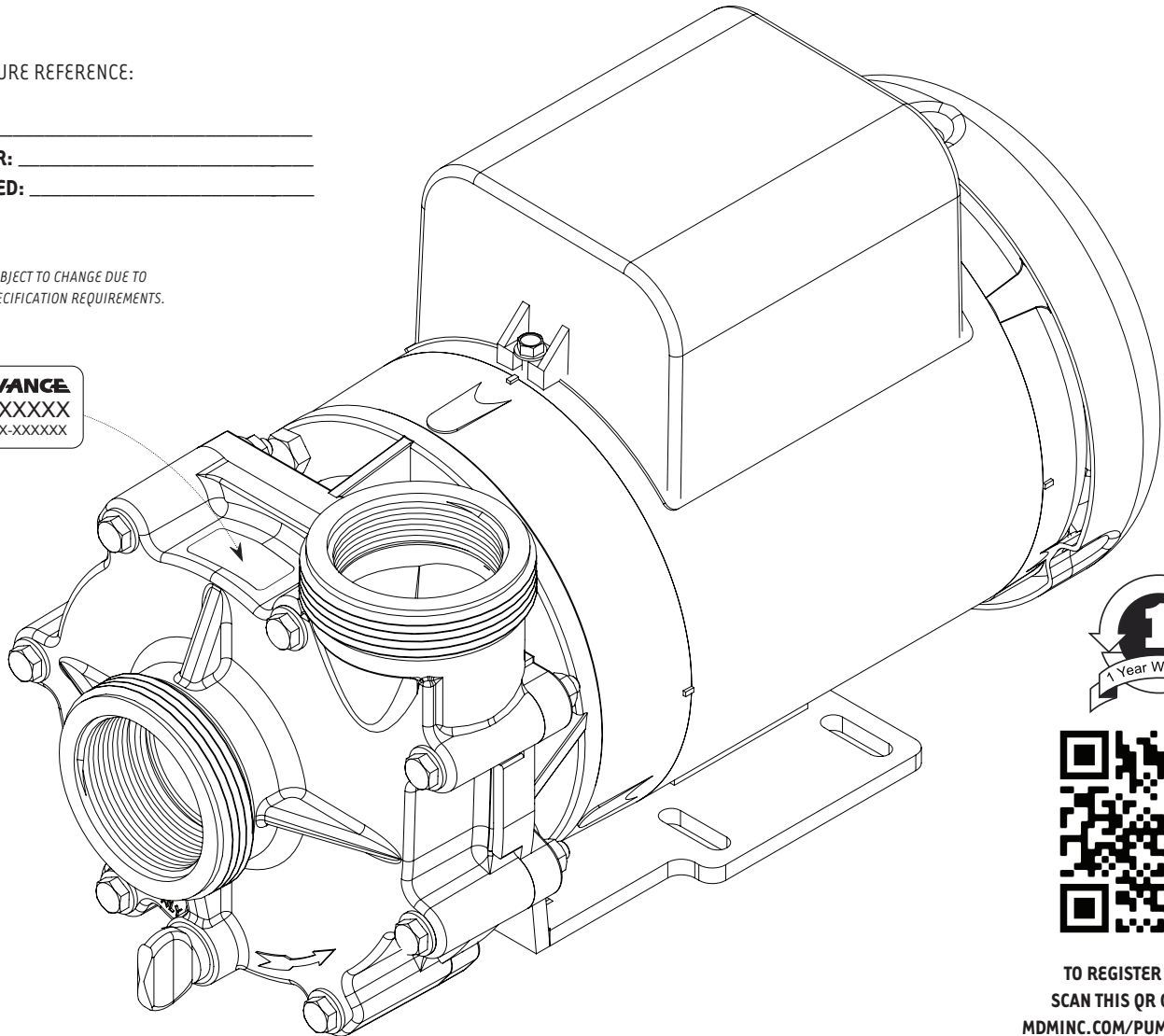

TO REGISTER YOUR PUMP  
 SCAN THIS QR CODE OR VISIT  
[MDMINC.COM/PUMP-REGISTRATION](http://MDMINC.COM/PUMP-REGISTRATION)

**TYPE:** END-SUCTION CENTRIFUGAL  
**MOTOR:** NEMA C FACE, 56J  
**HORSEPOWER:** 1/8 HP THROUGH 5 HP  
**INLET:** 2" FNPT AND BUTTRESS THREAD PORT  
**DISCHARGE:** 2" FNPT AND BUTTRESS THREAD PORT  
**MATERIAL:** 30% GLASS-FILLED NORYL® IMPELLER  
 40% GLASS-FILLED POLYPROPYLENE BRACKET & VOLUTE  
**HARDWARE:** STAINLESS STEEL

**SEAL OPTIONS:** STAINLESS STEEL WITH VARIOUS ELASTOMERS  
 NON-METALLIC IMPENATRA® SEAL WITH MULTIPLE CONFIGURATIONS FOR CHEMICAL COMPATIBILITY  
**OTHER OPTIONS:** EXTENSION COUPLED, PEDESTAL MOUNTED AND LONG-COUPLED WITH PEDESTAL MOUNTED PUMP ON FIBER-GLASS BASEPLATE. PUMP ENDS ALSO AVAILABLE  
**ACCESSORIES:** 500 CUBIC INCH STRAINER BASKET (2")  
 SWING CHECK VALVES (1.5", 2", 3")



Read completely before you install or operate your new pump. Do not allow this pump to become submerged.  
 Never run dry. Never reverse rotation. Use of a phase rotation meter is highly recommended to prevent damage to the pump.

Never exceed an internal case pressure of: 65 PSI



PROUDLY MADE  
 IN THE USA

*Corrosion-resistant, non-metallic pumps.*

© MDM INCORPORATED  
[WWW.MDMINC.COM](http://WWW.MDMINC.COM)

# **ADVANCE 4000**

We congratulate you on your choice of the Advance 4000 Centrifugal Pump. It has been carefully designed using the advantages of today's technology and carefully constructed to give you the dependability of yesterday. To insure proper performance, we urge you to carefully follow the instructions in this manual. If you have any questions, please call your supplier for assistance or visit [www.mdminc.com/support](http://www.mdminc.com/support).

## INSTALLATION

**PLEASE READ CAREFULLY. WHEN PROPERLY INSTALLED THE ADVANCE PUMP WILL PROVIDE DEPENDABLE TROUBLE-FREE SERVICE.**

1. Locate the pump as near the fluid source as possible. A flooded suction situation is preferred.
2. Mount motor base to a secure, immobile foundation.
3. Use only plastic fittings on both the intake and discharge ports. Seal pipe connections with Teflon<sup>®</sup> paste. These fittings should be self-supported and in neutral alignment with each port (i.e. Fittings must not be forced into alignment which may cause premature line failure or damage to the pump volute).
4. Never restrict the intake. Keep both input and discharge lines as free of elbows and valves as possible. Always use pipe of adequate diameter. This will reduce friction losses and maximize output.

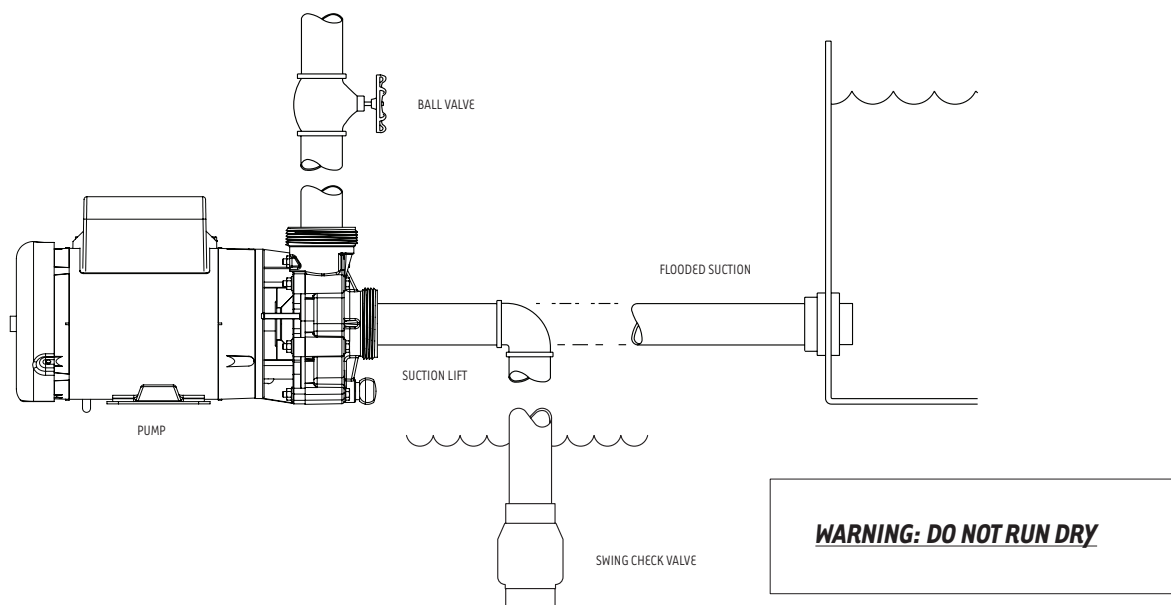

**WARNING: ALWAYS SHUT OFF ELECTRICAL POWER BEFORE INSTALLATION AND / OR SERVICING THIS PUMP.**  
ALL ELECTRICAL WIRING SHOULD MEET STATE AND LOCAL ORDINANCES. IMPROPER WIRING MAY NOT ONLY BE A SAFETY HAZARD BUT MAY PERMANENTLY DAMAGE THE MOTOR AND/OR PUMP. 230V 50 HZ MOTORS AVAILABLE - CONTACT YOUR SUPPLIER FOR INFORMATION.



## ELECTRICAL HOOK-UP

1. Check that supply voltages match the motor's requirements.
2. Check motor wiring and connect, according to instructions on motor, to match supply voltage.
3. For 3 phase motors, verify phase rotation with rotation meter. Incorrect rotation can cause serious damage to pump and/or motor. MDM Incorporated does not recommend checking rotation by quickly switching power on and off because serious damage can occur.
4. Power cord should be protected by conduit or by cable and be of proper gauge. It should be no longer than necessary.
5. Power should be drawn directly from a box with circuit breaker protection or with a fused disconnect switch.



PROUDLY MADE  
IN THE USA

***Corrosion-resistant, non-metallic pumps.***

© MDM INCORPORATED  
[WWW.MDMINC.COM](http://WWW.MDMINC.COM)

P.2

## PUMP END ASSEMBLY

- Electrically connect the motor so that the impeller will rotate counterclockwise when facing the pump with the motor toward the rear. **Warning:** Incorrect rotation will damage the pump and void the warranty. For 3 Phase Power: Electrically check rotation of impeller with volute disassembled from bracket. If pump end is assembled and rotation is incorrect, serious damage to pump end assembly can occur even if the switch is "quickly bumped." If rotation is incorrect, simply exchange any two leads.
- Clean and inspect all pump parts (O-ring, seal seats, motor shaft, etc.).
- Apply sealant to the bracket bore ID wall and around the seal case - follow sealant mfg. instructions. We recommend using Gasgacinch®, Permatex® or 3M® 1300L. Silicone sealant can also be used for seals with metallic casings (not for Impenatra® seal).
- Press seal head into bracket using a tool that is 1.5" (38mm) in width that will apply pressure to the seal case shoulder. **Warning:** Do not apply pressure to the carbon or silicon carbide seal head.
- Step A:** Place slinger (rubber washer) over motor shaft. **Step B:** Mount bracket to motor using four M bolts supplied using a 9/16" (15mm) ratchet wrench. **Step C:** Tighten bolts in a cross pattern to 60 in-lbs.
- Step A:** Carefully, lubricate the seal seat elastomer OD and impeller hub ID with water. **Step B:** Press the seal seat into the impeller hub making certain that the ceramic is in evenly - the sealing surface should be parallel with the impeller hub.
- Carefully lubricate carbon-graphite and ceramic sealing surfaces with clean water. **Warning:** Do not use silicon lubricants or grease.
- Step A:** Thread impeller onto shaft and tighten! If required, remove motor end-cap and use a screwdriver on the back of motor shaft to prevent shaft rotation while tightening. **Step B:** Replace motor end cap.
- Step A:** Seat large O-ring in volute O-ring channel. **Step B:** Assemble volute to bracket with the 1/4-20 x 2 3/4" hex cap screws, washers and nuts using two (x2) 7/16" (12mm) ratchet wrenches. **Step C:** Tighten in a cross pattern (60 in-lbs).
- Install drain plug with its O-ring in volute drain hole.
- Before operating pump, allow a proper cure time for the sealant used in step 3.

### TOOLS & MATERIALS

QTY	TOOLS / MATERIALS	USAGE
1	9/16" (15mm) WRENCH	TIGHTEN BRACKET BOLTS
2	7/16" (12mm) WRENCH	TIGHTEN VOLUTE BOLTS
2	1/2" (13mm) WRENCH ** FOR 3000'S	TIGHTEN BOLTS
1	FLATHEAD SCREWDRIVER	HOLD SHAFT IN PLACE
1	PLIERS	HOLD SHAFT IN PLACE
1	ROLL OF PAPER TOWELS	CLEAN HANDS AND PARTS
1	BOX OF LINT FREE TISSUE	CLEAN SEAL FACE SURFACES
1	CAN / TUBE GASGACINCH®, SILICONE SEALANT	FOR SEAL INSTALLATION
1	BOTTLE OF LUBRICANT, P-80, 3N1 OIL	FOR SEAL INSTALLATION
1	BOTTLE OF RUBBING ALCOHOL	CLEAN SEAL FACE SURFACES
1	ARBOR PRESS	1. TO PRESS SEAL INTO BRACKET 2. PRESS SEAT INTO IMPELLER
1	**HAMMER/ Mallet	**IF ARBOR PRESS IS NOT AVAILABLE
1	CHAMFERING TOOL	1. CHAMFER IMPELLER BORE EDGE 2. CHAMFER BRACKET BORE EDGE

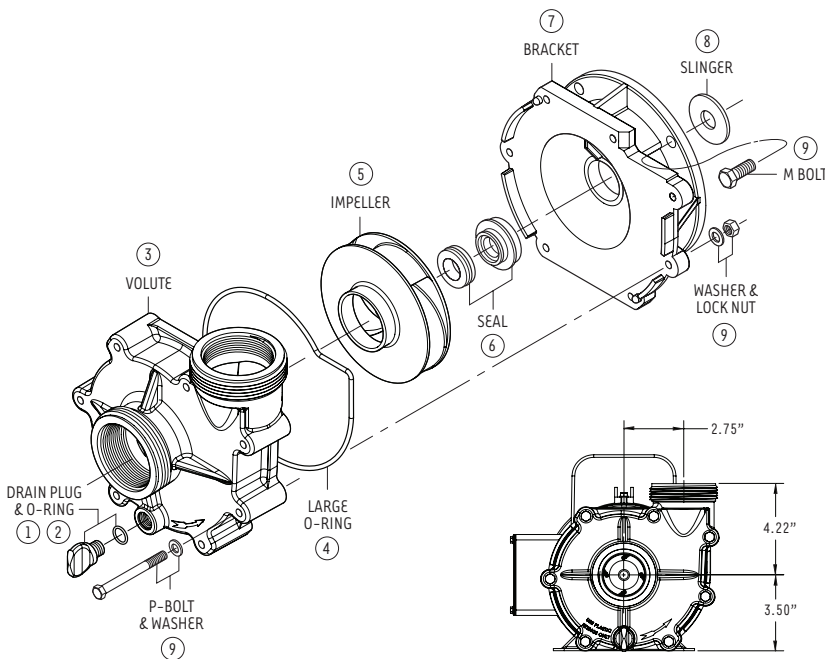

Pump end and motor illustrations are for reference only.

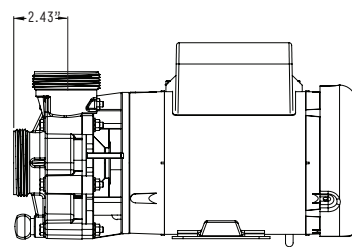

NO.	DESCRIPTION
1	DRAIN PLUG
2	O-RING (DRAIN PLUG)
3	VOLUTE
4	LARGE O-RING
5	IMPELLER
6	MECHANICAL SEAL
7	BRACKET
8	SLINGER
9	(7) P-BOLT, (7) PUMP NUT, (14) WASHER, (4) *M-BOLT

## DISASSEMBLY

- Step A:** Shut off power to motor before disconnecting any electrical wiring from the back of the motor. **Step B:** Remove drain plug to drain or empty out pump.
- Disassemble volute from bracket by removing the seven 1/4" - 20 x 2 3/4" hex cap screws with a 7/16" (12mm) wrench.
- Remove cap covering shaft at back of motor and with a large screwdriver. **Warning:** Prevent shaft rotation while unscrewing impeller.
- Remove ceramic piece from impeller with either a flat head screw driver or pliers. **Warning:** Eye protection is recommended when replacing the seal.
- Detach bracket from motor using a 9/16" (15mm) wrench.
- Remove mechanical seal from bracket by pressing out from the back. **Warning:** If you are replacing the seal, do not dig out from the front.

**WARNING: EYE PROTECTION IS STRONGLY RECOMMENDED**

## MAINTENANCE

\*The pump must be drained before servicing or if stored below freezing temperatures. Periodic replacement of seals may be required due to normal carbon wear.

### Lubrication

Motor - Permanently Lubricated ball bearings - no service required.

Rotary Seal - Requires no lubrication after assembly.

## TROUBLE SHOOTING AID

### **Motor Will Not Rotate**

1. Check for proper electrical connections to motor.
2. Check main power box for tripped circuit breaker.
3. Check thermal overload on motor.

### **Motor Hums Or Will Not Rotate At Correct Speed**

1. Check for proper electrical connections to motor and proper cord size and length.
2. Check for foreign material inside pump.
3. Remove volute and check for impeller rotation without excessive resistance.
4. Remove pump and check shaft rotation for excessive bearing noise.
5. Check start switch and/or capacitor.

### **Pump Operates With Little Or No Flow**

1. Check to insure that pump is primed.
2. Check for leaking seal.
3. Improper line voltage to motor or incorrect rotation.
4. Check for clogged inlet port and/or impeller.
5. Defective check or foot valve.
6. Check inlet lines for leakage, either fluid or air.

### **Pump Loses Prime**

1. Defective check or foot valve.
2. Inlet line air leakage.
3. Seal leaking.
4. Fluid supply low.

### **Motor Or Pump Overheats**

1. Check for proper line voltage and phase, also proper motor wiring.
2. Binding motor shaft or pump parts.
3. Inadequate ventilation.
4. Fluid being pumped should not exceed 194°F (90°C) for extended periods of time.



**MDM INCORPORATED**  
3345 N. Cascade Ave • Colorado Springs, CO • 80907  
Phone (719) 634-8202 • Fax (866) 425-1346  
[www.mdminc.com](http://www.mdminc.com) • [sales@mdminc.com](mailto:sales@mdminc.com)

Gasgacinch® is a registered trademark of Porter Manufacturing.  
Noryl® is a registered trademark of the General Electric Company.  
Teflon® is a registered trademark of the Chemours Corporation.  
Permatex® is a registered trademark of Illinois Tool Works Inc.  
Advance is a product of MDM Incorporated.  
Advance 4000 Installation Manual 2023.indd. Adobe Indesign CC. Updated 9/27/23.



PROUDLY MADE  
IN THE USA

**Corrosion-resistant, non-metallic pumps.**

© MDM INCORPORATED  
[WWW.MDMINC.COM](http://WWW.MDMINC.COM)

P.4