

Fill In Pump Information Below

Today's Date _____

Customer Info:

Company Name _____

First Name _____

Last Name _____

Email address _____

Phone Number _____

Physical Address of Pump Location _____

Model # _____

Serial Number _____

Purchase from which vendor _____

Performance target _____

This pump has been factory tested. Please inspect the entire Pump & Motor Unit for any damage that could have occurred in shipping and transportation.

MANUAL CONTENTS

- 1. PHYSICAL INSPECTION --> VOLUTE
- 2. PHYSICAL INSPECTION --> BRACKET
- 3. PHYSICAL INSPECTION --> IMPELLER
- 4. PHYSICAL INSPECTION --> MOTOR
- 5. PHYSICAL INSPECTION --> PLUMBING
- 6. PHYSICAL INSPECTION --> ELECTRICAL
- 7. PHYSICAL INSPECTION --> STATIC
HYDRAULIC TEST OF A MECHANICAL SEAL
- 8. COMMISSIONING --> START UP
- 9. COMMISSIONING --> MOTOR OPERATION
- 10.COMMISSIONING --> SYSTEM
PERFORMANCE VALIDATION

1. PHYSICAL INSPECTION ----> VOLUTE

STEP 1: Verify the Pump Casing Fasteners (THROUGH BOLTS) are securely tightened and the integrity of the plastic around them is not damaged.

STEP 2-3: Inspect the DISCHARGE and INLET. Verify there is no shipping damage.

STEP 4: Inspect the entire VOLUTE to confirm the integrity of plastic is not compromised.

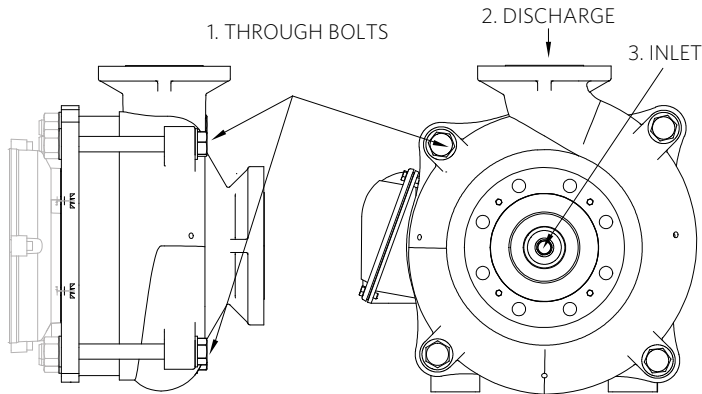

1

INITIAL HERE WHEN VERIFIED _____

3. PHYSICAL INSPECTION ----> IMPELLER

STEP 1: Verify the IMPELLER TURNS FREELY within the pump casing making sure nothing was damaged during transport.

STEP 2: Inspect IMPELLER VANES to make sure no shipping material or debris has made its way into the flow path.

STEP 3: Verify the MOTOR FAN turns freely while turning impeller.

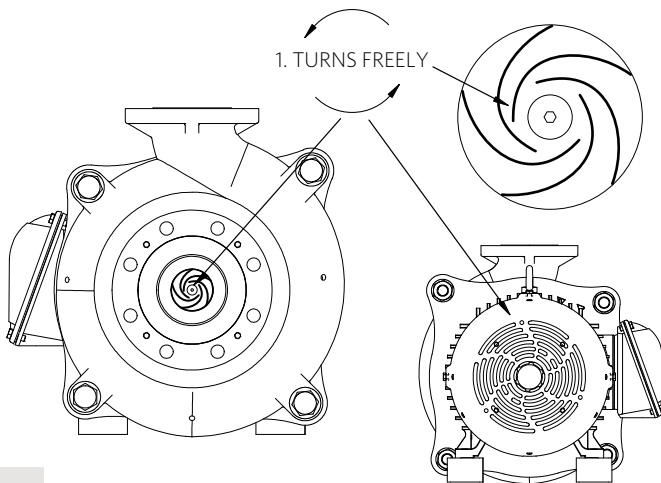

3

INITIAL HERE WHEN VERIFIED _____

2. PHYSICAL INSPECTION ----> BRACKET

STEP 1: Verify the four BRACKET BOLTS are securely fastening the bracket base to the motor face.

STEP 2: Inspect the entire BRACKET to confirm the integrity of plastic is not compromised.

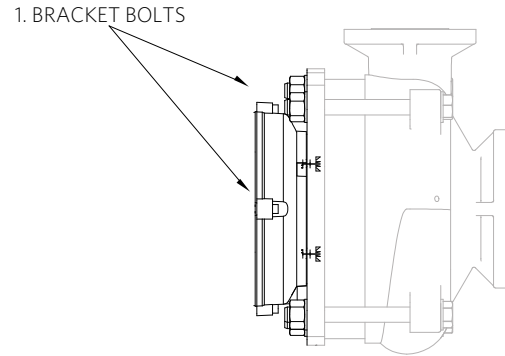

2

INITIAL HERE WHEN VERIFIED _____

4. PHYSICAL INSPECTION ----> MOTOR

STEP 1: Inspect the motor FAN & SHROUD making sure they are free of damage and that the FAN spins freely.

STEP 2: Inspect the motor FOOT and verify it sits flush to finished floor or PMU base.

STEP 3: Inspect motor SHAFT for damage.

STEP 4: Inspect the entire MOTOR to verify unit is free of visible damage.

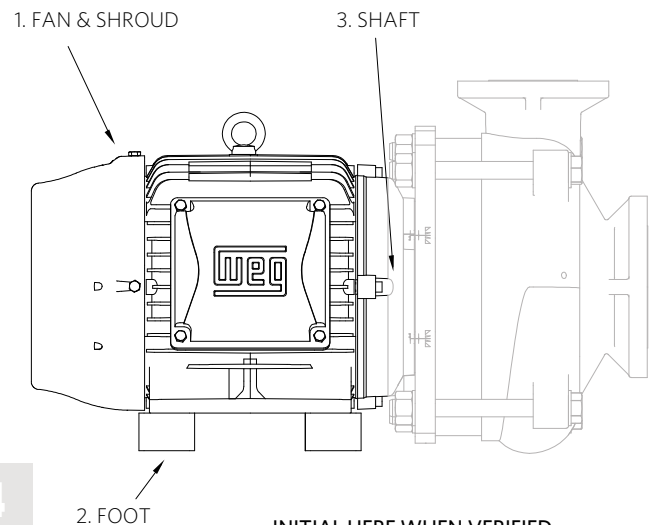

4

INITIAL HERE WHEN VERIFIED _____

5. PHYSICAL INSPECTION ----> PLUMBING

STEP 1: Make certain all inlet and discharge flange connections are positively sealed with gaskets and fasteners.

STEP 2: All plumbing connections in the system need to be positively sealed as well.

STEP 3: Inlet Pipe size **STEP 4:** Flooded Suction

STEP 5: Suction lift **STEP 6:** Discharge Pipe Size

Step 7: Pipe Load Supports - Make certain the pipe load is not transferring any stress to the pump end.

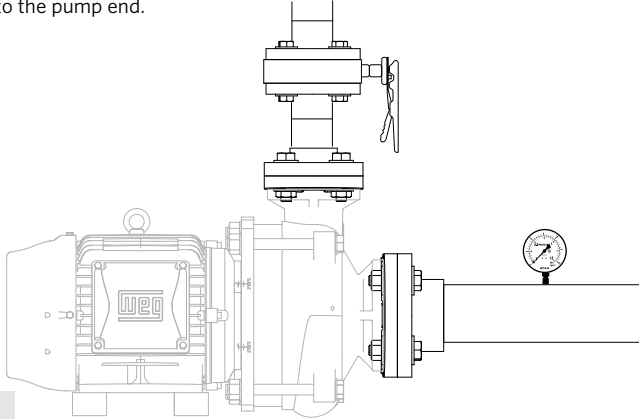

INITIAL HERE WHEN VERIFIED _____

7. PHYSICAL INSPECTION ----> STATIC HYDRAULIC TEST OF A MECHANICAL SEAL

STEP 1: PRIME PUMP END - Open all isolation valves to pump and make certain fluid fills pump end completely above discharge flange.

STEP 2: MECHANICAL SEAL INSPECTION - Visually inspect where motor shaft extends through pump bracket. Make certain no fluid is leaking around the pump bracket seal bore and motor shaft. If mechanical seal holds static system bore pressure then mechanical seal is ready to be tested under hydraulic load.

2. MECHANICAL SEAL INSPECTION

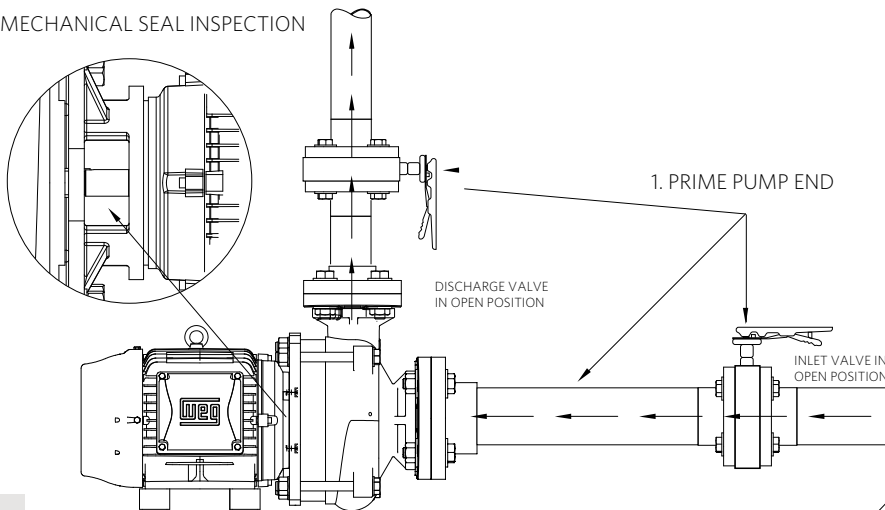

INITIAL HERE WHEN VERIFIED _____

6. PHYSICAL INSPECTION ----> ELECTRICAL

Proper electrical wiring is imperative in your pump / motor performance and longevity. Please verify that the supply electrical power matches the motor name plate before hard wiring motor.

Name Plate Data/Validation:

1. Supply Voltage _____ Phase _____
2. Motor Name Plate Voltage _____
3. Motor Name Plate FLA _____
4. Check Motor Rotation _____

See arrows on pump end for correct motor rotation.

Electrical Hook-Up:

1. Check that supply voltages match the motor's requirements.
2. Check motor wiring and connect, according to wiring diagram on motor, to match supply voltage.
3. Verify motor rotation with rotation meter.
4. Power supply wires should be SO cord or enclosed in conduit according to local electrical codes.
5. Power should be drawn from a circuit breaker panel with disconnect switch' according to local electrical codes.

WARNING: ALWAYS SHUT OFF ELECTRICAL POWER BEFORE INSTALLATION AND / OR SERVICING THIS PUMP! ALL ELECTRICAL WIRING SHOULD MEET STATE AND LOCAL ORDINANCES. IMPROPER WIRING MAY NOT ONLY BE A SAFETY HAZARD BUT MAY PERMANENTLY DAMAGE THE MOTOR AND/OR PUMP! 50 HZ MOTORS AVAILABLE - CONTACT YOUR SUPPLIER FOR INFORMATION.



1. JUNCTION BOX 2. NAME PLATE

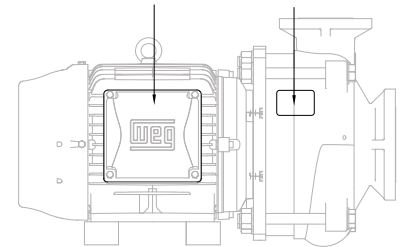

INITIAL HERE WHEN VERIFIED _____

8. COMMISSIONING ----> START UP

STEP 1: Energize the motor. **STEP 2:** Visually inspect the Mechanical Seal under hydraulic load. Confirm proper seat seating by verifying no sign of leaks around the motor shaft or seal bore on the pump bracket. **STEP 3:** Proceed to the "dead head" test. **A.** Slowly turn valve on discharge until completely closed. **B.** Visually inspect mechanical seal for leakage around the motor and seal bore on the pump bracket. **C.** If no dripping or leaking is present after 2 minutes of dead-head operation, seal has passed. **STEP 4:** Open discharge valve to fully open position.

1. ENERGIZE THE MOTOR

2. MECHANICAL SEAL INSPECTION

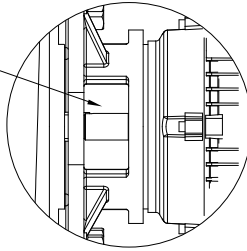
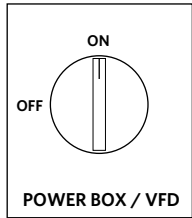

3. DISCHARGE VALVE IN CLOSED POSITION

INLET VALVE IN OPEN POSITION

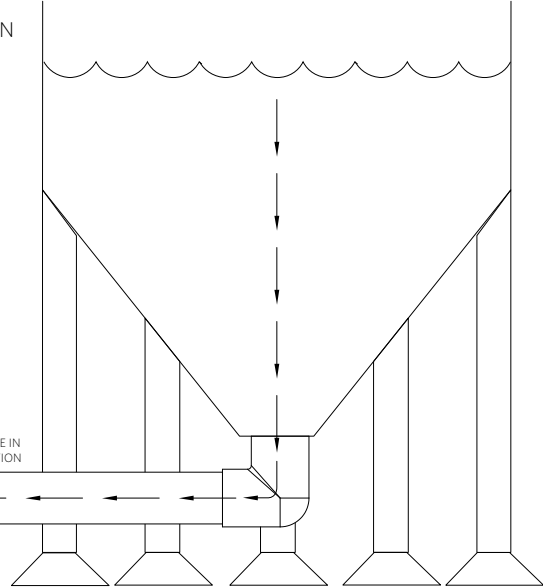

INITIAL HERE WHEN VERIFIED _____

8

9. COMMISSIONING ----> MOTOR OPERATION

Using an amp meter, immediately measure running amperage on the appropriate motor leads. Make certain the running amperage is not exceeding the rated full load amperage on the motor name plate.

Running amperage

Motor Shell Temp

2. MOTOR SHELL TEMP

1. RUNNING AMPERAGE

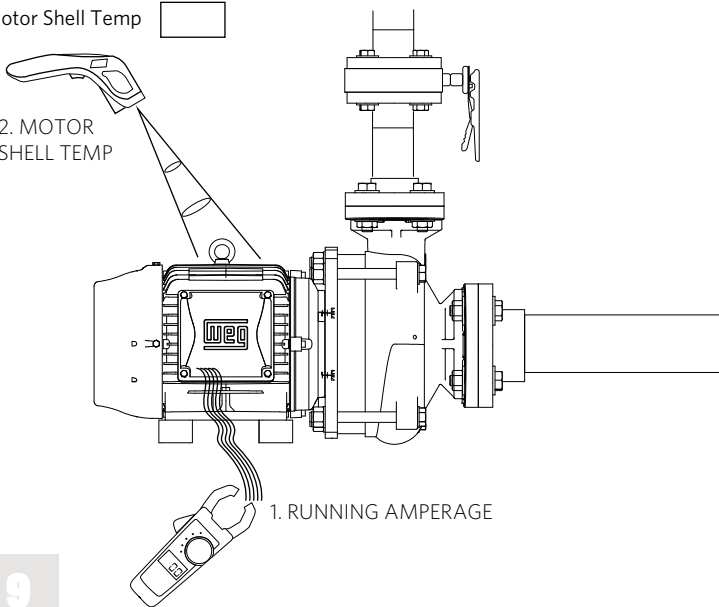

INITIAL HERE WHEN VERIFIED _____

9

10. COMMISSIONING ----> SYSTEM PERFORMANCE VALIDATION

Validate actual pump performance to the original performance target. This step is essential in assuring that the installation will perform to design.

Inlet pressure reading _____ Discharge pressure reading _____

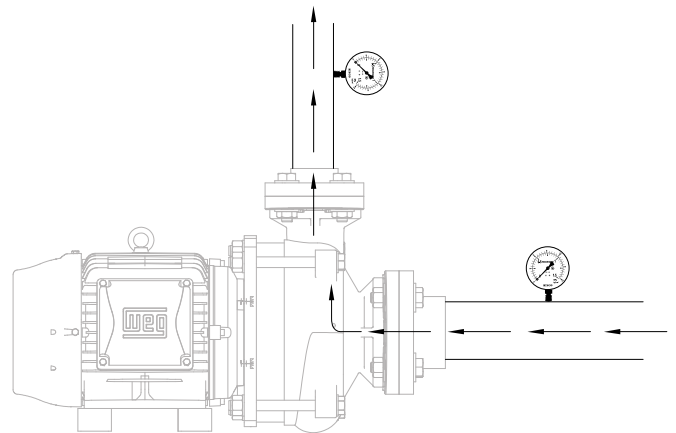

INITIAL HERE WHEN VERIFIED _____

10